

# The Circuitry of V1 and V2: Integration of Color, Form, and Motion

Lawrence C. Sincich and Jonathan C. Horton

Beckman Vision Center, University of California, San Francisco, California 94143;  
email: hortonj@vision.ucsf.edu, sincichl@vision.ucsf.edu

Annu. Rev. Neurosci.  
2005. 28:303–26

doi: 10.1146/  
annurev.neuro.28.061604.135731

Copyright © 2005 by  
Annual Reviews. All rights  
reserved

First published online as a  
Review in Advance on  
March 18, 2005

0147-006X/05/0721-  
0303\$20.00

## Key Words

striate cortex, extrastriate cortex, lateral geniculate nucleus, cytochrome oxidase, color vision

## Abstract

Primary and secondary visual cortex (V1 and V2) form the foundation of the cortical visual system. V1 transforms information received from the lateral geniculate nucleus (LGN) and distributes it to separate domains in V2 for transmission to higher visual areas. During the past 20 years, schemes for the functional organization of V1 and V2 have been based on a tripartite framework developed by Livingstone & Hubel (1988). Since then, new anatomical data have accumulated concerning V1's input, its internal circuitry, and its output to V2. These new data, along with physiological and imaging studies, now make it likely that the visual attributes of color, form, and motion are not neatly segregated by V1 into different stripe compartments in V2. Instead, there are just two main streams, originating from cytochrome oxidase patches and interpatches, that project to V2. Each stream is composed of a mixture of magno, parvo, and konio geniculate signals. Further studies are required to elucidate how the patches and interpatches differ in the output they convey to extrastriate cortex.

## Contents

INTRODUCTION.....	304
RESPONSE ARCHITECTURE	
OF V1.....	305
The Geniculate Input.....	305
Intracortical Circuitry in V1.....	307
Color, Form, and Motion in	
V1 Physiology.....	310
CONNECTIONS BETWEEN V1	
AND V2.....	312
Feedforward Connections.....	312
Feedback Connections.....	315
RESPONSE ARCHITECTURE	
OF V2.....	316
Intracortical Circuitry in V2.....	316
Physiology of the V2 Stripes.....	317
RECASTING THE VISUAL	
CORTICAL HIERARCHY.....	318

## INTRODUCTION

In the primate visual system, most of the signals leaving the retina are relayed through the lateral geniculate nucleus (LGN) to V1. Our review starts here in V1 and finishes in V2. We critically assess recent studies that have focused on the organization of these early cortical visual areas. Surveying their function in tandem seems sensible because V1 and V2 are linked intimately on several levels. Both areas are required for the highly evolved sense we commonly think of as “seeing” (Horton & Hoyt 1991). V1 sends most of its cortical output to V2 and in return receives a strong feedback projection. They contain similarly scaled retinotopic maps of the visual field, and both have comparable surface areas. Finally, each area manifests a unique metabolic signature—revealed through cytochrome oxidase (CO) histochemistry—that makes it instantly recognizable. This CO pattern forms the scaffold around which the intra- and intercortical wiring of V1 and V2 is organized. Our goal is to survey the progress made in understanding the function of V1 and V2 since it was last

reviewed in this series (Merigan & Maunsell 1993, Callaway 1998). The focus is on observations made in the macaque monkey, because it provides an unsurpassed animal model of the human visual system.

Although our knowledge has certainly grown since the trail blazing work of Hubel and Wiesel, it evokes a sense of humility to survey the progress in our field. For instance, ocular dominance columns were discovered more than 30 years ago but have yet to be invested with a function (Horton & Adams 2005). In biology, function can be notoriously hard to define. The cortex is a fairly uniform tissue adapted, like the skin, for many uses but for no one specific purpose. Neurons in V1 and V2 are not feature detectors, although they can detect features. We shy away from functional assignments and simply describe receptive field properties, recognizing that the most apt stimulus may not yet be known. It is still early in the exploration of the visual cortex and many fundamental premises are open to challenge.

In a key respect, the task of elucidating what Hubel & Wiesel (1962) dubbed the “functional architecture” of visual cortex has been quite fruitful. Originally, in the visual cortex this task involved determining if “there is any tendency for one or more of the [receptive field] characteristics to be shared by neighboring cells” (Hubel & Wiesel 1962, p. 128). Over the years, plentiful evidence has emerged that neurons are grouped within the cortical sheet according to shared response characteristics, although such grouping is not apparent cytoarchitecturally. The continuing empirical problem has been to identify columns of cells by their common features. The task has matured to include understanding how the physiological responses of neurons are sculpted from their inputs, how cells with common response features are interconnected, and how they organize their projections to other cortical areas (Callaway 1998, Lund et al. 2003).

As straightforward as it sounds, mapping the functional architecture of the visual has

---

### Cytochrome oxidase:

a mitochondrial enzyme, which can be used to identify particular visual areas (e.g., V1, V2) by its distinct laminar and columnar distribution.

**Column:** a group of neurons in cortex, clustered radially across at least two laminae, that share similar response properties

**Receptive field:** a delimited region in visual space for a given neuron, within which a light stimulus elicits a response

---

not been easy, for largely technical reasons. An ideal method would survey the cortex efficiently for the property under investigation and anchor it to an anatomical locus at high spatial resolution (50  $\mu\text{m}$  or less). Traditionally, neuroscientific techniques have relied on “point” methods such as single-cell recording and tracer microinjections. Using such methods to study the organization of columns within a vast expanse of tissue like V1 has obvious limitations. Hubel & Wiesel (1977) called it “a dismaying exercise in tedium, like trying to cut the back lawn with a pair of nail scissors” (p. 28). Single-cell recordings can be correlated with functional architecture by making electrolytic lesions or by depositing fiducial markers along an electrode track. However, accurate alignment of electrode penetrations with individual recording sites in the tissue can be exasperatingly difficult. This problem, and the trend towards experiments in behaving animals, has made histological confirmation of recording sites a vanishing standard. The advent of optical imaging and functional magnetic resonance imaging has overcome the “point” limitation, but these new techniques suffer from poor spatial and temporal resolution, as well as uncertainty regarding the

signal source. We emphasize these practical issues because progress in our field has been hampered by methodological hurdles.

## RESPONSE ARCHITECTURE OF V1

V1 is the largest single area in the cerebral cortex of the macaque (Felleman & Van Essen 1991). It averages 1343  $\text{mm}^2$ , out of a total cortical surface area of  $\sim 10,000 \text{mm}^2$  (Sincich et al. 2003). According to Livingstone & Hubel (1984a; 1987; 1988), it transforms the three input streams from the LGN into three output streams headed to area V2 (**Figure 1**). This view, however, has begun to erode, undercut by new studies at various levels of the visual pathway that violate the tripartite model of V1 organization. Beginning with the LGN, we examine new anatomical and physiological data that require a fresh consideration of the information flow through V1 and V2.

### The Geniculate Input

The LGN contains six major laminae, evident in sections stained for Nissl substance. There are four dorsal parvocellular laminae and two

---

**Optical imaging:** a physiological method of mapping the responsiveness of cortex, using reflected light or voltage-sensitive dyes as probes.

---

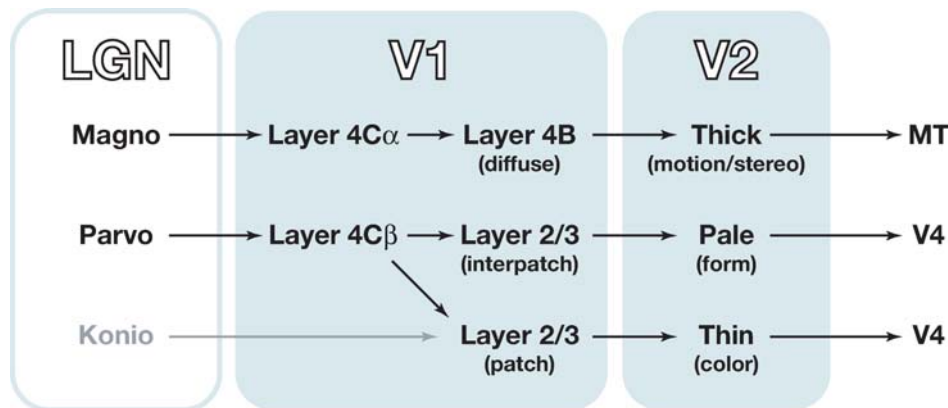

**Figure 1**

The tripartite model of the visual system. In layer 2/3, parvocellular input splits into two streams, patches and interpatches, segregating color and form signals that are propagated to V2 and subsequently to V4. Magnocellular signals travel via layer 4B to V2 and area MT, conveying information about motion and stereo. Koniocellular input is added to the color stream in layer 2/3 patches. After Livingstone & Hubel (1988) and Van Essen & Gallant (1994).

ventral magnocellular laminae. The parvo laminae receive input from color-opponent midget ganglion cells, whereas the magno laminae are supplied by broadband parasol ganglion cells (Perry et al. 1984). These distinct retinal channels account for the duality of receptive field properties in the LGN. Most parvo cells have color-opponent center-surround receptive fields, e.g., a red on-center and a green off-surround. Magno cells, by comparison, are broadband because their field center and surround receive input from the same mixture of cone types (Wiesel & Hubel 1966, Schiller & Malpeli 1978, Lee et al. 1998, Reid & Shapley 2002). At any given eccentricity, parvo cells have a higher spatial resolution, lower contrast sensitivity, slower conduction velocity, and a more sustained response than do magno cells (Shapley et al. 1981). The output of parvo and magno cells in the LGN is segregated in the primary visual cortex. Parvo cells terminate in layer 4C $\beta$  and the upper part of layer 6, whereas magno cells innervate layer 4C $\alpha$  and the lower part of layer 6. These distinct anatomical projections persuaded early investigators that parvo and magno channels remain functionally isolated in V1. In fact, as we shall see, they intermingle extensively beyond their input layers.

Livingstone & Hubel (1988) proposed that the parvo and magno systems provide the basis for the segregation of function in the visual system. They pointed out that one's sense of depth is impaired when a colored image is presented against an isoluminant background. Such isoluminant stimuli appear invisible to the magno system's "color blind" cells. Therefore, they reasoned, the loss of depth sensation at isoluminance indicates that magno cells handle stereo perception. In addition, they noted that the sensation of motion dissolves when a moving red/green grating becomes isoluminant, which suggests that motion perception also belongs to the magno channel. This seemed a good choice because magno cells conduct more rapidly than do parvo cells—an advantage perhaps for the perception of motion.

The parvo system was assigned the job of color perception—an easy decision given that only parvo cells have color-opponent receptive fields. This left the problem of form perception. Weighing the evidence, Livingstone and Hubel decided that perceiving form should be a parvo function because parvo cells have the best spatial resolution. However, parvo cells also serve color perception, creating an uncomfortable overlap. At this point, Livingstone and Hubel asserted that although form-perceiving neurons receive input from color-coded parvo geniculate layers, most are not explicitly color coded. They concluded that in the form pathway, "color-coded parvocellular input is pooled in such a way that color contrast can be used to identify borders but that the information about the colors (including black versus white) forming the border is lost" (Livingstone & Hubel 1988, p. 742). Thus, a split was promulgated in the receptive field properties of parvo-derived cortical cells, stripping color coding from those cells involved in the perception of form.

A third, neglected class of cells was later discovered in thin leaflets of tissue intercalated between the classical magno and parvo layers. These additional geniculate laminae were first recognized in the prosimian, where they are better developed than in the macaque. They were called "konio cellular," referring to the small size of the cells that they contain (Kaas et al. 1978), and it is worth noting that they numerically equal the magno population (Blasco et al. 1999). Many cells in the konio layers exhibit strong immunoreactivity for the  $\alpha$ -subunit of type II calmodulin-dependent protein kinase (Hendry & Yoshioka 1994). The reason is unclear, but the enzyme provides a handy chemical label to identify the elusive konio layers. By coincidence, a special bistratified blue-on, yellow-off retinal ganglion cell was discovered in the macaque retina just at the time when konio cells were identified firmly as a third class of geniculate cells (Dacey & Lee 1994). This led immediately to speculation that blue-yellow retinal ganglion cells provide input to the konio

laminae. In support of this idea, preliminary evidence has emerged that blue-yellow ganglion cells project to the konio layers just ventral to the third and fourth parvocellular layers (Calkins & Hendry 1996). Identifying the properties and connections of konio cells in the LGN has been a struggle because these cells are clustered in thin laminae or in occasional nests of cells embedded within the principal magno and parvo laminae. To complicate matters, konio cells constitute a heterogeneous population of cells, some lacking blue-yellow color opponency (Hendry & Reid 2000) and immunoreactivity for  $\alpha$ -subunit of type II calmodulin-dependent protein kinase (Sincich et al. 2004). Certain subpopulations project directly to extrastriate cortex, conveying visual information that bypasses V1 altogether (Yukie & Iwai 1981, Rodman et al. 2001, Sincich et al. 2004). Nonetheless, to many investigators the term konio has become synonymous with the blue-yellow pathway, just as parvo is now equated, too simplistically, with the red-green pathway.

The projections of konio cells are segregated from those of parvo and magno cells in V1. Retrograde tracer studies have shown that konio cells provide the only direct geniculate input to layers 1–3 (Hendry & Yoshioka 1994). The innervation of layer 4A is uncertain. It contains a dense but thin tier of geniculate input organized into a fine, reticular pattern that resembles a honeycomb. Single geniculate afferents either ramify in 4A alone or send collaterals into layer 2/3 (Blasdel & Lund 1983). This implies that the projection to layer 4A is derived from konio cells. Chatterjee & Callaway (2003) have recorded from isolated geniculate afferents in V1 after application of muscimol to silence cortical cells. Sketches of their electrode penetrations and lesions show that exclusively konio afferents are encountered in layer 4A, as well as in the upper layers. However, Yazar et al. (2004) have found that some geniculate fibers terminate in both layers 4C $\beta$  and 4A, implying either a direct parvo input to 4A or a konio input to 4C $\beta$ .

## Intracortical Circuitry in V1

CO histochemistry provides valuable information about the organization of V1 in several different ways (**Figure 2**). First, it delineates the cortical layers more crisply than the traditional Nissl stain. Second, CO density in each layer parallels the strength of geniculate input, with greatest activity in layers 6, 4C, 4A, and 2/3 (Fitzpatrick et al. 1983, Horton 1984, Hendry & Yoshioka 1994, Ding & Casagrande 1997). Third, CO reveals a striking array of dark patches (blobs, puffs) present in all layers except 4C and 4A (Hendrickson et al. 1981, Horton & Hubel 1981, Horton 1984, Wong-Riley & Carroll 1984). These patches are separated by paler zones, known logically as interpatches. The transition from patches to interpatches is gradual. Most investigators arbitrarily assign about a third of the cortical surface area to CO patches. The direct konio input to the upper layers coincides perfectly with the patches (Fitzpatrick et al. 1983, Horton 1984, Hendry & Yoshioka 1994).

The discovery that magno, parvo, and konio projections terminate in separate layers has spurred a concerted effort to learn if their signals remain segregated as they filter through the intracortical circuits of V1. One could imagine three isolated, parallel cortical systems operating in V1 to transfer pure magno, parvo, and konio signals to V2. As we shall see, in fact, the organization of cortical circuits in V1 suggests that geniculate channels are combined. Various anatomical approaches allow dissection of cellular networks in the cortex. The traditional Golgi method, or more modern dye-filling techniques, permits reconstruction of single cells along with their dendrites and axonal projections. By studying enough examples of cells in various layers, one can hypothesize about how cortical circuits are put together. Another strategy involves extracellular injection of small amounts of tracer into single layers, with a goal of delineating the connections with other cortical layers. Both these

## Figure 2

Macaque V1 patches and V2 stripes. A montage prepared from tissue sections cut tangentially to the cortical surface reveals characteristic patterns of endogenous metabolic activity when processed for CO. (*Bottom*) In V1 a fine array of patches is visible. (*Top*) In V2 a more irregular pattern is present, consisting of pale, thin (*arrows*) and thick (*brackets*) stripes arranged in repeating cycles.



approaches suffer from the limitation that they indicate only the potential for synapses to occur wherever axon terminals and dendrites coincide. They do not reveal anything direct about actual cell-to-cell transmission of information through the cortex. Two new methods have been developed to address this latter issue. The first uses transmission of rabies virus across a synapse, followed by immunochemical labeling of the chain of infected cells (Ugolini 1995). The second uses laser photostimulation to release caged glutamate, thereby revealing the inputs from various layers onto a single cell (Callaway & Katz 1993).

New evidence has emerged about the flow of signals within V1 (**Figure 3**). Parvo inputs to the layer  $4C\beta$  synapse principally on glutamatergic spiny stellate cells. These cells project in turn to layers 2/3, where about half their synaptic connections are made (Callaway & Wiser 1996, Yabuta & Callaway 1998b). On their way, however, they make numerous synapses in layer  $4C\beta$  itself, as well as in layers  $4C\alpha$ , 4B, and 4A. This implies immedi-

ate mixing with magno ( $4C\alpha$ ) and konio (4A) streams, but one cannot be certain because the synapses made in layer 4 actually may be upon the dendrites of cells located in other layers. This uncertainty underscores the difficulty of inferring circuitry from isolated single-cell morphology. There are conflicting data concerning the projections from  $4C\beta$  to patches versus interpatches in layer 3. After extracellular biocytin injections, Lachica et al. (1992) found projections to interpatches and patches from  $4C\beta$ , whereas Yoshioka et al. (1994) found a direct projection only to interpatches. Yabuta & Callaway (1998b) believe that  $4C\beta$  projects to both patches and interpatches, but their data are limited to reconstruction of just seven intracellularly filled cells.

Magno inputs terminate in layer  $4C\alpha$ . Cells in this layer project to all superficial layers, as well as to  $4C\alpha$  itself. Most investigators emphasize that layer  $4C\alpha$  projects to layer 4B, endowing it with a strong magno bias. However, it actually sends a denser projection to layer 2/3. This projection probably terminates

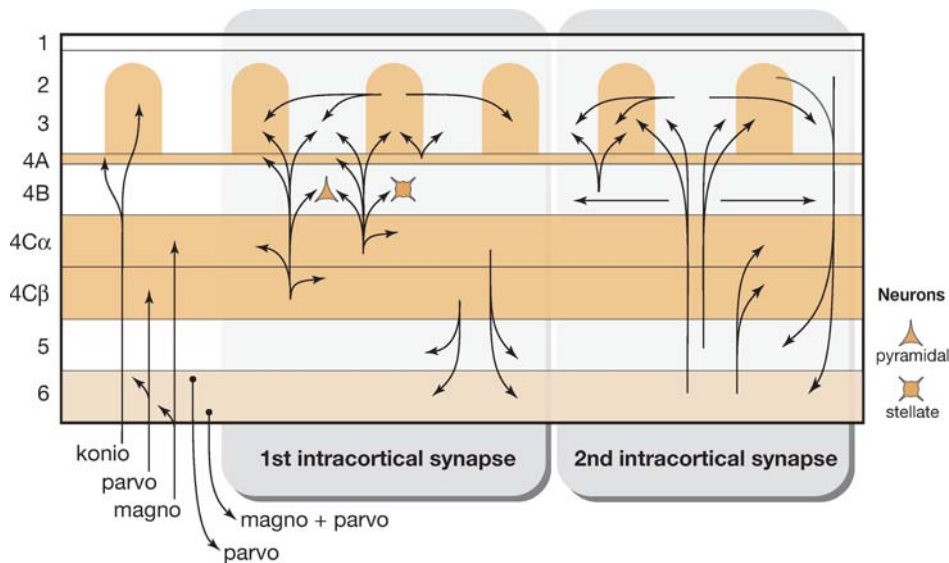

**Figure 3**

Intracortical circuitry within V1. (*Left*) The three geniculate streams entering V1 terminate in the CO-dense layers and the patches of layer 2/3. (*Middle*) Projections forming the first intracortical synapse yield a blend of the parvo-, magno-, and koniocellular streams. Each geniculate-recipient layer or patch sends axons to interpatches and to other layers or patches. In layer 4B, pyramidal and stellate cells receive different laminar inputs. (*Right*) In the second stage of intracortical projections, the axons continue to mingle the V1 signals, especially between infra- and supragranular layers, with increasing emphasis on horizontal projections. The relative strength of projections is not shown in this schematic diagram, nor is the diversity of cell types and classes comprising the intracortical wiring.

in both patches and interpatches (Yoshioka et al. 1994, Callaway & Wiser 1996), although one study reported that it supplies only patches (Lachica et al. 1992).

Thus, the projection patterns of cells in layer 4C reveal the potential for convergence of all three geniculate channels at their very next tier of synaptic contacts. For example, individual layer 2/3 cells are in a position to receive direct konio input and trans-synaptic parvo and magno input from layer 4C. However, it remains uncertain to what extent single cells actually blend multiple geniculate channels. In principle, cortical neurons might preserve strict segregation through precisely elaborated connections made on a cell-by-cell basis, overcoming the apparent intermingling of parvo, magno, and konio in layers beyond the first cortical synapse. Physiological studies of laminar projections have shown that this is usually not the case.

Callaway and colleagues have recorded from cells in macaque tissue slices, using laser photostimulation to survey the input sources to layers 3B, 4B, 5, and 6 (Sawatari & Callaway 1996, 2000; Briggs & Callaway 2001; Yabuta et al. 2001; Briggs & Callaway 2005). On the whole, these studies demonstrate a wide spectrum of laminar combinations in the input to cells in each of these layers. Of particular interest are layers 4B and 3B because many of their neurons receive input directly from parvo and magno cells in layer 4C. Recordings from four stellate cells in 4B showed significant activity only when stimulation was applied to layer 4C $\alpha$ , rather than 4C $\beta$ . These limited recordings, which reflect the challenge of acquiring these valuable data, suggest that 4B stellate cells are driven only by magno input (Yabuta et al. 2001). Layer 4B pyramidal cells ( $n = 14$ ), by contrast, have mixed input from 4C $\alpha$  and 4C $\beta$ , with twofold more

**Orientation**

**selectivity:** the dependence of a visual neuron's firing rate on the orientation (e.g., horizontal) of a contrast edge or line segment presented in the receptive field.

excitation from  $4C\alpha$ . Because stellate and pyramidal cells both project to V2 (Rockland 1992), there is little doubt that a combined magno plus parvo signal is conveyed by layer 4B to V2. In layer 3B the cells in patches and interpatches receive input from parvo ( $4C\beta$ ), magno ( $4C\alpha$ ), konio (4A), or mixed (4B) layers, in a range of relative synaptic strengths (Sawatari & Callaway 2000). Most layer 3B cells project locally, almost entirely within layer 2/3, providing a substrate for further mingling of geniculate channels. They also provide a major source of projections to V2.

Infragranular circuits provide further potential for cross talk between geniculate channels. Cells in both  $4C\alpha$  and  $4C\beta$  project to layers 5 and 6 (Lund & Boothe 1975, Callaway & Wiser 1996). Cells in layers 5 and 6 project up to layer 2/3, which is reciprocally connected back to layers 5 and 6. Cells in layer 6 project back to layer 4C. The function of these reciprocal intracortical loops is not known, but it seems unlikely that the feedback they convey respects the distinction between parvo, magno, and konio. Feedback from layer 6 to the LGN is segregated only partially with respect to magno and parvo, further mixing the geniculate channels (Fitzpatrick et al. 1994).

From these data, it is evident that the intracortical wiring of V1 blurs the distinctiveness of thalamic input by convergence of parvo, magno, and konio signals onto individual cells. Rabies virus provides another means to probe how signals are combined in the visual system by revealing the chain of direct synaptic connections through the cortex. Nassi & Callaway (2004) have injected it into area MT and found infected cells in layers 4B and  $4C\alpha$  of V1. Virtually no infected cells were located in  $4C\beta$ . These preliminary data indicate that the 4B projection to MT is dominated by the magno geniculate channel.

### Color, Form, and Motion in V1 Physiology

The anatomical studies reviewed above imply that magno, parvo, and konio inputs intermin-

gle extensively within V1. Moreover, in layer 2/3 both patches and interpatches receive signals derived from all three geniculate sources. Regardless of the anatomy, the paramount issue is how cells with different receptive field properties are segregated into different functional compartments. Livingstone & Hubel (1988) originally proposed that three main classes of V1 neurons transmit visual signals to V2. Their central hypothesis, in simplest form, was that (a) Layer 2/3 patches convey information about color. Most patch cells are unoriented, center-surround, and color-opponent. (b) Layer 2/3 interpatches convey information about form. Interpatch cells are orientation tuned but not color coded. (c) Layer 4B conveys information about motion and stereo. Its cells are orientation and direction selective but are not tuned for color.

Early studies reporting that color is specifically processed by unoriented cells in CO patches deserve a closer look. These cells are a key feature of the tripartite model because they were described as the origin of a color pathway to V2. Livingstone & Hubel (1984a) made tangential electrode penetrations through the cortex, correlating clusters of unoriented cells with CO patches by making occasional lesions. In these experiments, the color properties of unoriented cells were not addressed. After they had pinned down the association between patches and unoriented cells, they next tested 204 unoriented cells for their color properties. These cells were assumed to be situated in CO patches because they lacked orientation tuning. However, no histological evidence was adduced to show their location. Of the 204 unoriented cells, 133 (65%) were rated as "color coded," establishing the link between CO patches and color. For comparison, of 698 oriented cells, only 148 (21%) were deemed color selective.

More direct evidence implicating patches in color processing was offered subsequently by Ts'o & Gilbert (1988). In their study, clusters of unoriented color cells were identified. The location of these clusters was later compared with the pattern of CO activity.

There was some degree of coincidence between patches and color cells (see their figure 8). Ts'o & Gilbert also made the remarkable observation that some CO patches contain a predominance of red/green cells, whereas others are more richly endowed with blue/yellow cells. This segregation is difficult to reconcile with the fact that all patches get direct blue/yellow konio input and indirect red/green parvo input. The association between unoriented color cells and CO patches has been corroborated by one other study (Yoshioka & Dow 1996). These authors sampled seven cells in patches and found that four were color-coded and unoriented.

Other reports have not confirmed that CO patches are populated by unoriented, color-opponent cells. Leventhal et al. (1995) found no correlation between orientation tuning, color properties, and CO patches. However, corroborative histological data from their electrode tracks were not illustrated. Edwards et al. (1995) and O'Keefe et al. (1998) reported no difference in the orientation tuning of patches and interpatches. In these two studies, color properties were not examined. To date, therefore, the color/patches versus orientation/interpatches dichotomy, derived from the correlation of electrode recordings with anatomy, is not conclusive.

Over the intervening years, studies in anesthetized and awake macaques using cone-isolating stimuli have found that color and orientation are treated as independent features by most cortical neurons. Cells that respond to achromatic, luminance contrast can also respond selectively to color. In addition, orientation-selective cells are frequently color tuned (Thorell et al. 1984, Lennie et al. 1990, Leventhal et al. 1995, Cottaris & DeValois 1998, Vidyasagar et al. 2002, Wachtler et al. 2003, Horwitz et al. 2004). A careful study of color selectivity by layer (Johnson et al. 2001) revealed that cells responsive to isoluminant color (though to varying degrees) are present in all layers, including 4B, which is supposed to be color-blind. The authors found that just 21% of color cells in V1 are unoriented.

This result has been confirmed by Friedman et al. (2003), who reported that only 17% of color-coded units are unoriented. However, Conway (2001) asserts that 80% of color cells are unoriented (Livingstone & Hubel's Class "D" cells). These papers are contradictory, in part because different criteria were used to define orientation and color selectivity.

Imaging studies have also addressed the issue of color and form segregation, subtracting activation due to an isoluminant, chromatic grating from activity evoked by an achromatic, luminance grating. In principle, this differential imaging strategy can isolate color regions in the cortex for subsequent correlation with CO histology. Using optical imaging, Landisman & Ts'o (2002) found zones of high color selectivity in V1 that overlap with CO patches in some instances but not in others. The stimuli were based on isoluminance measures in humans, which are known to differ significantly from those in macaques (Dobkins et al. 2000). Tootell et al. (2004) used a dual-label deoxyglucose technique to show that CO-rich areas of V1 have the strongest uptake of label to color stimuli. The stimuli in this study were tuned to isoluminance by gauging visually evoked potentials (VEPs) to a chromatic grating. Possible limitations of this study include cross talk between the two radioactive labels and difficulty assuring isoluminance with evoked potentials. Collectively, the data from electrode and imaging studies make it difficult to conclude that color properties are the sole province of CO patches in V1.

Livingstone & Hubel (1984a) assigned motion processing to layer 4B because its cells were direction tuned, color nonselective, and apparently magno-dominated. They recorded from 33 "nonblob" cells in layer 4B and reported that two thirds were strongly direction selective. Only five "blob" cells were recorded without any comment on their direction tuning. Subsequent studies have confirmed that direction tuning is prominent in layer 4B, although it is found in other layers as well (Hawken et al. 1988, Ringach et al. 2002, Gur et al. 2005). Some cells in 4B,

---

**Flatmounting:** a tissue-dissection technique whereby the cerebral cortex is unfolded and flattened to reveal histological patterns in a plane parallel to the pial surface.

---

as well as layer 6, exhibit an extremely pronounced direction bias (Livingstone & Hubel 1984a, Hawken et al. 1988). This feature is a striking property of V1 cells that project to MT (Movshon & Newsome 1996) and may be independent of the CO pattern (Leventhal et al. 1995). The projection from layer 4B, which arises from patches and interpatches, probably contributes to the high degree of direction tuning among MT cells. It remains to be proven that cells in layer 4B that project to V2 thick stripes are highly direction biased. Their properties could be different, given that independent populations of cells in layer 4B project to V2 and MT (Sincich & Horton 2003).

## CONNECTIONS BETWEEN V1 AND V2

### Feedforward Connections

When CO histochemistry was applied to area V2, it yielded a spectacular pattern of coarse, parallel stripes running perpendicular to the V1 border (Horton 1984), divided into repeating cycles of pale-thick-pale-thin (Tootell et al. 1983). Livingstone & Hubel (1984a, 1987), motivated by the idea that areas with comparable levels of CO might be wired together, were first to study the anatomical relationship between patches in V1 and stripes in V2. They found that patches project to thin stripes and that interpatches project to pale stripes. These connections were reported to arise exclusively from layer 2/3. A diffuse projection was described from patches and interpatches in layer 4B to thick stripes. The discovery of three distinct V1 compartments, each providing exclusive input to a type of V2 stripe, provided an enticing clue to the segregation of visual function. Insight into the nature of this functional segregation was furnished by two lines of evidence, which emerged nearly simultaneously. First, investigators showed that thick stripes project to area MT, a region concerned with the perception of motion and stereo, whereas thin

and pale stripes project to V4, a region implicated in color and form (DeYoe & Van Essen 1985, Shipp & Zeki 1985). Second, a physiological study of receptive field properties in V2 showed marked segregation according to stripe type (DeYoe & Van Essen 1985, Hubel & Livingstone 1987). Synthesizing these data, Livingstone & Hubel (1988) proposed the following: patch → thin stripe handles color, interpatch → pale stripe processes form, and that layer 4B → thick stripe mediates motion and depth (**Figure 1**). The latter pathway was postulated to be dominated by the magno geniculate input, in contrast to the projections to pale and thin stripes, which were said to be derived principally from the parvo (and later konio) geniculate channel. This tripartite view of the V1-to-V2 pathway has prevailed in visual neuroscience, despite occasional complaints that it is overly reductive (Martin 1988, Merigan & Maunsell 1993).

The strongest piece of evidence in favor of three parallel functional streams (form, color, and stereo/motion) has been Livingstone and Hubel's demonstration of three distinct anatomical projections uniting compartments in V1 and V2. New evidence has emerged that their description of the V1-to-V2 pathway in the macaque was incomplete. Experiments exploiting improvements in tracers and flatmounting techniques have revealed a different pattern of projections between V1 and V2. These findings have rendered the old tripartite model untenable and suggest instead that the V1-to-V2 pathway is organized into a bipartite system (Sincich & Horton 2002a). This new anatomical foundation inclines one to take a more critical look at old physiological data that were interpreted in light of the defunct tripartite model.

Before turning to the physiology, it is worth inquiring why mapping the V1-to-V2 pathway has been such a difficult endeavor. Most of area V2 is buried in the lunate sulcus in the macaque. Only a few millimeters lie exposed on the brain surface, where tracers can be injected under direct visualization. As a result, sections cut tangentially to the pia

contain only a sliver of V2. From this fragment of V2 tissue it is often difficult to distinguish between the two CO-dark stripes (thick and thin) or to tell when a transition has occurred between stripes. This problem can be mitigated by dissecting the cortex from the white matter, unfolding it, and flattening it like a sheet (Olavarria & Van Sluyters 1985, Tootell & Silverman 1985). Using this technique, a bird's eye view of V1 and V2 is obtained, facilitating the identification of stripes in V2 (**Figure 2**) (Olavarria & Van Essen 1997, Sincich et al. 2003). Even in such preparations, however, it can be impossible to discriminate thick and thin stripes. For some reason, in macaques the thin and thick stripes are not always clearly defined.

The difficulty of recognizing V2 stripes in some macaques means that data from many injections must be discarded. One can analyze cases only where the identity of a stripe is unequivocal and luck yields a tracer injection perfectly confined to a single stripe. In our reexamination of the V1-to-V2 projections, only 77 of 187 injections met these criteria (Sincich & Horton 2002a). However, they provided a consistent picture of the anatomy (**Figure 4**). The projection to thin stripes arose from patches, most strongly from layer 2/3. However, cells in layers 4A, 4B, and 5/6 also contributed to thin stripes. Cells in the deeper layers tended to be located in patches but were less tightly clustered than the cells in layer 2/3. Tracer injections into pale stripes revealed labeled cells in layer 2/3 interpatches, as expected. In addition, many cells were present in layers 4A, 4B, and 5/6, loosely concentrated in interpatches. Surprisingly, thick stripe injections yielded a pattern of labeling identical to that produced by pale stripe injections.

How does this new description of the V1-to-V2 projections differ from the old account? Previously, according to the tripartite model, each V2 stripe type was believed to receive a different input, derived from a single layer. Instead, it has become clear that multiple layers project to each stripe type and that the pro-

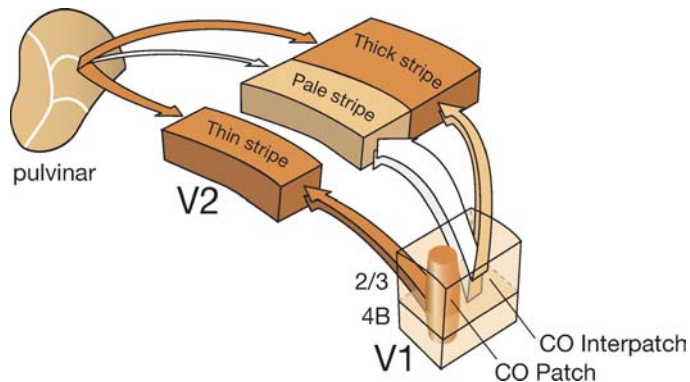

**Figure 4**

Projections from V1 to V2. Two major pathways originate from separate CO compartments in V1: Neurons in CO patch columns project to V2 thin stripes, and cells in interpatch columns project to pale and thick stripes. The axon terminal fields of these projections are densest in pale stripes. Other projections (*not shown*) arise from layers 4A, 5, and 6. The pulvinar provides the main thalamic input to V2, and the density of its projections is complementary to those from V1.

jections are bipartite, with patches connecting to thin stripes and interpatches connecting to both pale and thick stripes. This result implies that pale and thick stripes receive the same input from V1, rather than different messages concerned with form and stereo/motion, respectively. This notion was tested directly by making paired injections of different tracers into adjacent thick and pale stripes (Sincich & Horton 2002a). About a third of V1 projection neurons were double-labeled, showing that a substantial number of interpatch neurons form a single pathway to both pale and thick stripes. There may be subpopulations within interpatches that carry separate visual signals to pale and thick V2 stripes, but this idea is unproven. It is more likely that many cells remained single-labeled simply because their terminal arbors were smaller than a single V2 stripe (Rockland & Virga 1990). The segregation between CO patch and interpatch streams is nearly perfect, as demonstrated by using different tracers deposited into neighboring pale and thin stripes. In these cases, only a handful of double-labeled neurons was found out of thousands of single-labeled cells (**Figure 5**) (Horton & Sincich 2004).

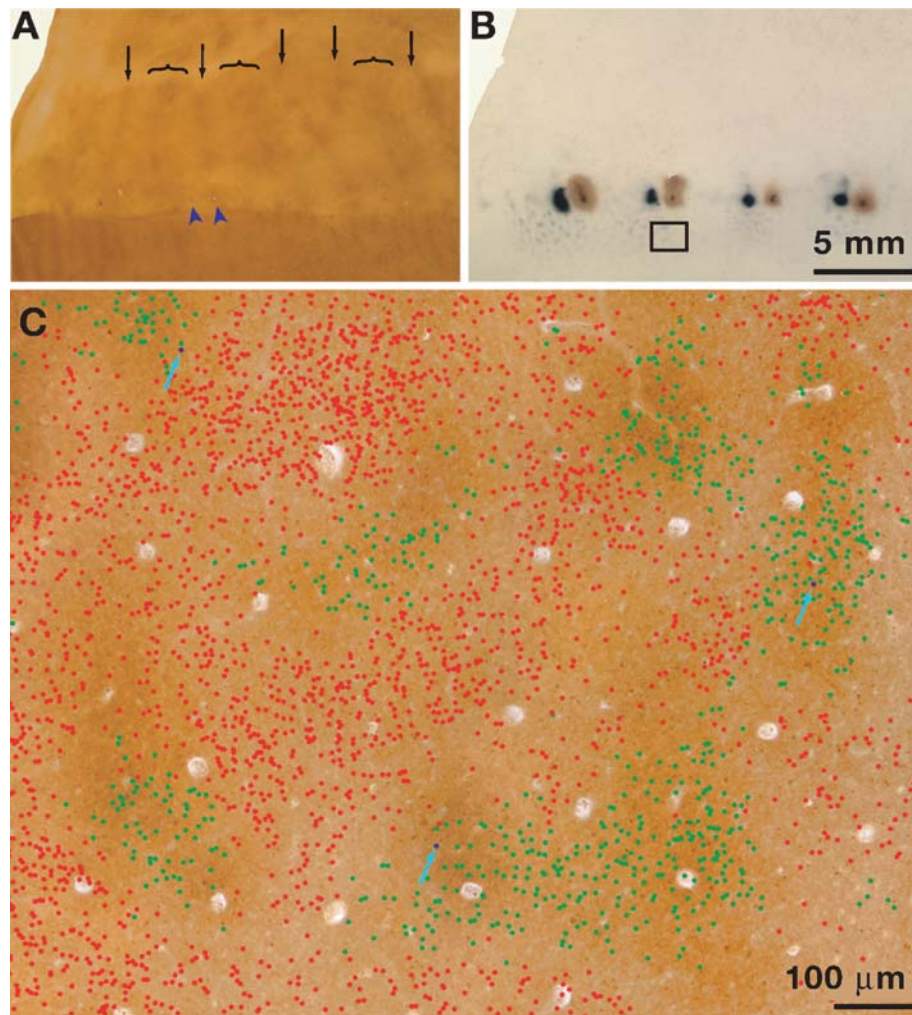

**Figure 5**

Segregation of V1-to-V2 projections. (A) Single CO-stained section from layer 4 in V2, showing the stripe pattern (brackets, thick stripes; arrows, thin stripes). One of the thin stripes splits to form a “Y”; such stripe bifurcations occasionally interrupt the regular stripe sequence. Blue arrowheads indicate the location of a CTB-Au injection in a pale stripe (left) and a WGA-HRP injection in a thin stripe (right). (B) A section more superficial to the one shown in (A), processed for both tracers. Black box is the area where cells are plotted and shown at higher power below. (C) Cells counted in box are superimposed onto the CO pattern from an adjacent section. Neurons projecting to the thin stripe (green,  $n = 703$ ) were located in CO patches, whereas those projecting to the pale stripe (red,  $n = 2058$ ) were situated in the interpatches. Of the 2761 cells in this single section, 3 were double-labeled (blue, arrows), demonstrating the high degree of segregation between these two pathways. Adapted from Horton & Sincich (2004).

If pale stripes and thick stripes receive input from the same source in V1, what accounts for their differing CO intensity? One possibility is that thick stripes receive stronger input from V1 than do pale stripes, endowing

them with higher metabolic activity. Before the advent of CO histochemistry, investigators observed that V1 projections to V2 terminate in regular clusters (Wong-Riley 1978). These clusters were later shown to coincide

with pale stripes (Sincich & Horton 2002b). It runs counter to intuition that the stripes receiving the strongest V1 input should have the weakest metabolic activity.

V2 also receives a major projection from the pulvinar. Its input coincides faithfully with the density of CO staining in V2, perhaps accounting for the increased metabolism of thin and thick stripes (Livingstone & Hubel 1982, Levitt et al. 1995). Pulvinar terminals synapse largely in lower layer 3, whereas V1 input is richer to layer 4 (Rockland & Pandya 1979, Lund et al. 1981, Weller & Kaas 1983, Van Essen et al. 1986, Rockland & Virga 1990). Therefore, the terminal fields of both the pulvinar and V1 are continuous throughout V2, but their densities wax and wane in counterphase and they favor different layers. The dovetailed pulvinar input must exert an influence on the physiological properties of cells in V2, but it has been largely ignored. It provides the first opportunity for the pulvinar to join the flow of information in the cortical visual pathway. The pulvinar is considered a higher-order thalamic relay because it inherits many of its response properties from descending cortical projections, especially from V1, and then projects back to cortex (Sherman & Guillery 1996, Shipp 2001). Therefore, a major source of V1 input to V2 stripes is channeled via the pulvinar. We do not know if this loop originates from distinct CO compartments in V1. Until the nature of the massive pulvinar input to V2 is more clearly defined, it seems premature to assign functions to the CO stripes.

### Feedback Connections

Compared with the feedforward V1-to-V2 pathway, the feedback projection has received little attention. Numerically, it is nearly as large. Beneath each square millimeter of cortex, there are an estimated 11,000 feedback neurons in V2 compared with 14,000 feedforward neurons in V1 (Rockland 1997). The feedback neurons reside in layer 2, upper layer 3, and layer 6, situated at least one synapse

downstream from V1's input (Tigges et al. 1973, Rockland & Pandya 1981, Weller & Kaas 1983, Kennedy & Bullier 1985). Their axons terminate in layers 1, 2, and 5 of V1, with occasional arbors in layer 3 (Rockland & Virga 1989). A recent study using tritiated amino acids also reported feedback projections to layer 4B (Gattass et al. 1997), although this has not been confirmed by others.

Few studies have asked how the V2 feedback projections are organized with respect to the response architecture of V1. It would be of exceptional interest to know if they differentially target the patches or interpatches. Four studies have reported that the projections form terminal clusters in V1, suggesting a systematic relationship (Wong-Riley 1979, Malach et al. 1994, Angelucci et al. 2002, Shmuel et al. 2005). Comparison was made with CO-stained sections in only one study. Feedback projections from pale and thick stripes were correlated with V1 interpatches as well as with orientation columns (Shmuel et al. 2005). A separate study using an adenoviral anterograde tracer concluded from two pale stripe injections that axons project back diffusely to V1, without clustering in CO patches or columns of the same orientation (Stettler et al. 2002). The distribution of synaptic boutons was not analyzed, making this interpretation problematic. A third injection did reveal a periodic pattern (on a suitable scale of 0.5 mm), but no relationship with orientation columns was observed. The correspondence with CO patches was not examined. Further studies are warranted to probe the organization of V2-to-V1 feedback.

Retrograde tracer injections have shown that V2 gets two thirds of its entire cortical input from V1 (Sincich et al. 2003). Cells in V2 become completely unresponsive after loss of this physiological drive (Schiller & Malpeli 1977, Girard & Bullier 1989). However, the reverse is not true. Withdrawal of V2 feedback by cooling or GABA injections produces surprisingly subtle changes in the responses of V1 neurons. Sandell & Schiller (1982) found no change in orientation tuning

and only occasional changes in direction selectivity, although some cells became less responsive. Hupe et al. (2001) report no impact of V2 inactivation on V1 cells' classic receptive fields or on their modulatory surrounds.

## RESPONSE ARCHITECTURE OF V2

V2 is the second largest cortical area in the macaque, with a mean area of 1012 mm<sup>2</sup> (Sincich et al. 2003). The representation of visual space in V1 is mirrored across the border in V2 (Allman & Kaas 1974, Gattass et al. 1981, Sereno et al. 1995). Given that V2 is subdivided into 26–34 cycles of stripes that encircle V1 like a corona, it is intriguing to ask whether their presence has any impact on local retinotopic order. At one extreme, each stripe type could represent the visual field independently. In that case, V2 might contain three separate, interleaved visual field maps. Two groups have extensively mapped V2 at high resolution, making electrode recordings that traversed several sets of stripes (Roe & Ts'o 1995, Shipp & Zeki 2002b). Investigators paid particular attention to stripe borders, where a sudden jump in receptive field position might be expected. In addition, evidence was sought that for any given stripe type, retinotopy progresses smoothly from stripe to stripe. The data provide some support for the idea that V2 contains independent maps for each stripe type, but this interpretation is weakened by the receptive field scatter, the gradual transition from one stripe type to another, and the small size of field-position jumps between stripe types. Even if one accepts that V2 stripes contain independent retinotopic maps, that property alone would not warrant dividing V2 into three visual areas.

### Intracortical Circuitry in V2

The interlaminar circuitry of V2 has been virtually ignored. Our small store of information is derived entirely from Golgi stud-

ies (Valverde 1978, Lund et al. 1981). Neurons in layer 4 project chiefly to layers 3A and 3B. Neurons in 3B, which receive most of the pulvinar input, project to layers 2 and 3A. These layers are the major source of projections to other cortical areas (Rockland 1997). Axons heading to other cortical areas usually have collaterals in layer 5. As in V1, layer 5 neurons form a population of recurrent projections, sending axons to layers 2/3 and 5, as well as to noncortical targets like the pulvinar. Finally, layer 6 neurons appear to differ from those in V1 because they send local projections largely to layer 3 rather than layer 4. The apparent lack of recurrent projections to layer 4 suggests that it may be the only layer that retains response properties reflecting the original V1 input. No studies have examined whether the interlaminar circuitry differs between CO stripe types.

Extensive signal mixing via intralaminar projections occurs across V2 stripes. Within layers 2/3 and 5, horizontal axon projections form periodic terminal clusters, as in V1 (Rockland 1985). Anterograde tracer injections in any individual stripe consistently reveal a set of lateral projections to every stripe type (Levitt et al. 1994b, Malach et al. 1994). Pale stripes project equally to thin and thick stripes as well as to pale stripes. Interestingly, dark CO stripes are more likely to project to other dark stripes, permitting cross talk between thin and thick stripes and, by implication, between pulvinar inputs. The extent of horizontal projections is about 8 mm, twice that of lateral projections in V1, perhaps contributing to the coarser retinotopy of V2. Each terminal cluster is ~250 μm across, much less than the dimension of a V2 stripe. Columns within V2 stripes have been suggested by physiological and optical imaging studies. The terminal clusters may bear a systematic relationship to purported V2 columns, but this question has not been pursued in the macaque.

The most important insight from these studies of V2 circuitry is that local projections make little effort to confine themselves

to the same class of stripe. Therefore, even if it were correct that V1 sends a different signal to each class of V2 stripe, these signals are shared quite freely between V2 stripes. This contrasts with the situation in V1, where CO patches project preferentially to other patches, and interpatches to interpatches (Livingstone & Hubel 1984b, Yoshioka et al. 1996, Yabuta & Callaway 1998a).

### Physiology of the V2 Stripes

The physiology of cells in V2 has been studied extensively. We focus explicitly on efforts to correlate receptive field properties and stripe class, setting aside a growing list of interesting studies that address the role of V2 in attention-guided behavior (Ghose et al. 2002) and in the processing of complex stimuli (Kobatake & Tanaka 1994, Ito & Komatsu 2004).

DeYoe & Van Essen (1985) found that color-selective cells were prevalent in both thin and pale stripes, whereas orientation-selective cells were less common in these compartments. Hubel & Livingstone (1987) recorded from 1023 single cells but provided no numerical breakdown of cell properties by stripe class. However, they stated that, with some exceptions, unoriented color-tuned cells were located in thin stripes, oriented cells (which showed no overt color coding) were present in pale stripes, and disparity-tuned cells were concentrated in thick stripes [although “occasional disparity-tuned cells occurred in pale stripes” (p. 3410)]. Their analysis depended on the squirrel monkey because they were unable to distinguish between thick and thin stripes in the macaque. Often stimuli were used selectively in the assessment of receptive fields, injecting a potential bias in their analysis. For example, color responses were not tested systematically in oriented cells, nor disparity tuning in unoriented cells. Nonetheless, their data provided the basis for a link between color and thin stripes, form and pale stripes, and stereo/motion and thick stripes.

Since these original reports, no fewer than 11 studies have reexamined how receptive field properties correlate with different V2 stripe classes (Peterhans & von der Heydt 1993, Levitt et al. 1994a, Roe & Ts'o 1995, Gegenfurtner et al. 1996, Tamura et al. 1996, Yoshioka & Dow 1996, Kiper et al. 1997, Roe & Ts'o 1999, Ts'o et al. 2001, Moutoussis & Zeki 2002, Shipp & Zeki 2002a). These studies are difficult to compare because they differ in their methods, as well as in their criteria for defining a cell as “selective” for any given parameter. No study, with the exception of Shipp & Zeki (2002a), shows electrode tracks marked with lesions in sections containing easily distinguishable cycles of thin-pale-thick-pale CO stripes. It is impossible to say much about the functional specificity of each stripe class without reliable correlation of recording sites with histology. Faced with this difficulty, some investigators have given up trying to use CO to define stripe class. Instead, for example, they use a stimulus thought to activate preferentially color-selective cells, and they define these regions as “thin stripes” (Xiao et al. 2003). It would be preferable to define stripes by their CO appearance because the association between color-selective cells and thin stripes is not yet well established.

The studies mentioned above are quite contradictory; some studies found a high degree of functional segregation by stripe type, and others concluded that little evidence exists to support this idea. Only one property appears in all studies as a robust feature: a higher degree of orientation selectivity in thick and pale stripes. As mentioned above, some studies suggest that color selectivity is more prevalent in thin stripes, but others dissent (Peterhans & von der Heydt 1993, Levitt et al. 1994a, Gegenfurtner et al. 1996, Tamura et al. 1996). The only study containing a laminar analysis of cell properties found that the peak functional “distinctiveness” of the stripes occurs in layer 3 (Shipp & Zeki 2002a). This layer receives the bulk of pulvinar input and also sends the strongest projection to higher visual areas. Ultimately, it is the

functional specificity of the output cells within different stripe classes that reflects most meaningfully how V2 segregates the signals it receives from V1.

Optical imaging is an effective technique for the correlation of receptive field properties with anatomical compartments because it allows one to collect signals averaged simultaneously from thousands of cells. In the macaque, however, most of V2 is buried in the lunate sulcus, and the small portion situated on the surface lies close to large vessels that produce vascular artifact. In the squirrel monkey, V2 is a more inviting target because it sits in a flat expanse of exposed cortex. In this species, Malach et al. (1994) have shown that orientation columns are prominent in thick and pale stripes but not in thin stripes. This result has been confirmed in the macaque (Vanduffel et al. 2002) and owl monkey (Xu et al. 2004). It is consistent with the verdict from single-cell recordings. Curiously, Xu et al. report that only every other pale stripe has high orientation selectivity.

In the macaque, imaging studies have localized color-selective regions to the thin stripes in V2 (Roe & Ts'o 1995, Xiao et al. 2003, Tootell et al. 2004). In these studies, the response to high-contrast, achromatic gratings was subtracted from the response to an isoluminant, chromatic grating. As mentioned earlier, in monkeys it is difficult to be sure that a stimulus is truly isoluminant. The stimulus can be rendered nearly, but not exactly, isoluminant. Therefore, the comparison may really entail a low-contrast chromatic grating versus a high-contrast black-and-white grating. Many color-selective cells respond well to both stimuli, complicating the interpretation of these experiments. The use of color-exchange stimuli, which equate form and contrast but vary chrominance, are superior for imaging color-specific regions (Wade et al. 2002). Doubt will remain about the localization of color-selective cells until such stimuli are applied to image the stripe compartments in V2.

## RECASTING THE VISUAL CORTICAL HIERARCHY

V1 provides the foundation for the visual cortical hierarchy. Although it projects to a number of different cortical areas, most of its output is directed to V2. To understand vision, it is crucial to know what signals V1 conveys to V2. For nearly two decades, our understanding of the V1-to-V2 circuit has rested on the belief that three channels exist, each carrying different information: (a) color from layer 2/3 patches to thin stripes, (b) form from layer 2/3 interpatches to pale stripes, (c) stereo/motion from layer 4B to thick stripes. New findings have called into question this tripartite model of the visual system.

Initially, the discovery that blue-yellow color information is fed directly to patches (and not interpatches) seemed to boost the idea that patches are a color specialization. On the other hand, a direct konio projection to patches exists in the owl monkey, a nocturnal species that lacks color vision (Horton 1984, Casagrande & Kaas 1994, Xu et al. 2004). Perhaps the owl monkey is an exception among primates, making the macaque a more suitable model for humans. In the macaque, however, the konio input to patches appears to be accompanied by a diffuse input to layer 4A. This input to layer 4A has no predilection for patch columns, implying that both patches and interpatches are supplied with ascending konio input from layer 4A. Parvo input from layer 4C $\beta$  also appears to be transmitted to both patches and interpatches in layer 2/3. To summarize, there is plenty of evidence that geniculate color information is funneled to both patches and interpatches. This makes it improbable that only patches convey color information to V2.

It has also become clear that inputs to V1, which are stratified by magno, parvo, and konio, become thoroughly intermingled by passage through the elaborate circuitry of V1. As a result, output cells of V1 probably convey a mixed, but transformed, geniculate signal to V2. The old scheme stipulated

that only layer 4B projects to thick stripes, carrying a magno signal for stereopsis and motion. This idea has become untenable for several reasons. First, layer 4B gets both parvo and magno input (Yabuta et al. 2001). Second, lesions of magnocellular geniculate laminae have no effect on stereopsis (Schiller et al. 1990). Third, disparity-tuned cells are abundant outside layer 4B (Poggio et al. 1988) and thick stripes (DeYoe & Van Essen 1985, Peterhans & von der Heydt 1993). Fourth, other layers besides 4B project to thick stripes (Sincich & Horton 2002a).

Originally, interpatches were assigned the job of form perception because they were thought to contain oriented cells that lack color tuning. Parenthetically, we point out the flawed logic of assuming that a given V1 compartment constitutes the form pathway merely because it contains cells that are oriented. Cells in 4C $\beta$  are unoriented, but who would argue that they are not part of the form pathway? All cells in V1 contribute to the perception of form, oriented or not. The specious notion that oriented cells are not color selective, and hence serve form but not color, derived from a failure to test oriented cells carefully for their color properties. It also reflected a shrewd bit of guesswork, predicated on the remarkable clinical phenomenon of cerebral achromatopsia. Patients with this rare syndrome perceive the world without color. This rare deficit, produced by a lesion in the fusiform gyrus, proves that perception of form and color eventually becomes divorced in the visual system. However, it is unlikely that their separation occurs as early as V1 and V2.

The pattern of projections from V1 to V2 is actually simpler than proposed by Livingstone & Hubel (1988). Instead of three output channels, there are only two. These two channels are defined by CO compartments. Patches project to thin stripes; interpatches supply pale stripes and thick stripes (**Figure 4**). These projections are columnar because they arise from cells coarsely aligned

in layers 2/3, 4A, 4B, 5, and 6. Most of the input to thin stripes is supplied by layer 2/3; pale and thick stripes get strong projections from layers 2/3 and 4B. It should be emphasized that pale stripes and thick stripes receive their input from the same compartment (interpatches) and often from the same cells. This vitiates the proposal that pale stripes get parvo input and thick stripes get magno input.

What functions are dichotomized by patches and interpatches? Embarrassingly, the answer remains elusive, nearly a quarter century after the discovery of CO patches. We must learn if patches are endowed selectively with unoriented, color-opponent cells, as originally described. Do they coincide with orientation singularities (“pinwheels”), where orientation columns seem to converge? For technical reasons, alluded to earlier, a clean verdict has not been forthcoming from single-cell electrode recordings or optical imaging. Perhaps 2-photon confocal imaging of calcium fluxes will furnish the technical breakthrough required to resolve these issues (Ohki et al. 2005). It provides simultaneous information about the physiological responses of hundreds of cells at high spatial resolution. With fluorescent tracers it should be possible to backfill cells in V1, allowing one to focus particular attention on the projection neurons that go to V2. Finally, it may yield data concerning the properties of cells in V2 stripes, where intrinsic signal imaging has been disappointing.

One reason that the tripartite form/color/motion model for the visual system has survived so long is that there is nothing available to replace it. For a neuroscience textbook or an undergraduate class, it provides a compelling story. It would be refreshing, as we conclude, to offer a new, comprehensive picture of the functional organization of V1 and V2. At this point we can offer only a more accurate account of the anatomical projections between these key early visual areas to provide a new foundation for future studies.

---

**CO:** cytochrome oxidase

**GABA:** gamma-aminobutyric acid (inhibitory neurotransmitter)

**LGN:** lateral geniculate nucleus

**MT:** middle temporal area (also named cortical area V5)

**V1:** primary visual cortex, striate cortex

**V2:** secondary visual cortex

**VEP:** visual evoked potentials (scalp recordings)

---

## ACKNOWLEDGMENTS

The work was supported by The Larry L. Hillblom Foundation and by National Eye Institute grants to L.C.S., J.C.H., and the Beckman Vision Center. Additional support was provided by a National Institutes of Health core grant to the California Regional Primate Research Center.

## LITERATURE CITED

- Allman JM, Kaas JH. 1974. The organization of the second visual area (V II) in the owl monkey: a second order transformation of the visual hemifield. *Brain Res.* 76(2):247–65
- Angelucci A, Levitt JB, Walton EJ, Hupe JM, Bullier J, Lund JS. 2002. Circuits for local and global signal integration in primary visual cortex. *J. Neurosci.* 22(19):8633–46
- Blasco B, Avendano C, Cavada C. 1999. A stereological analysis of the lateral geniculate nucleus in adult *Macaca nemestrina* monkeys. *Vis. Neurosci.* 16:933–41
- Blasdel GG, Lund JS. 1983. Termination of afferent axons in macaque striate cortex. *J. Neurosci.* 3(7):1389–413
- Briggs F, Callaway EM. 2001. Layer-specific input to distinct cell types in layer 6 of monkey primary visual cortex. *J. Neurosci.* 21(10):3600–8
- Briggs F, Callaway EM. 2005. Laminar patterns of local excitatory input to layer 5 neurons in macaque primary visual cortex. *Cereb. Cortex.* In press
- Calkins DJ, Hendry SH. 1996. A retinogeniculate pathway expresses the alpha subunit of CaM II kinase in the primate. *Soc. Neurosci. Abstr.* 22:1447
- Callaway EM. 1998. Local circuits in primary visual cortex of the macaque monkey. *Annu. Rev. Neurosci.* 21:47–74
- Callaway EM, Katz LC. 1993. Photostimulation using caged glutamate reveals functional circuitry in living brain slices. *Proc. Natl. Acad. Sci. USA* 90(16):7661–65
- Callaway EM, Wiser AK. 1996. Contributions of individual layer 2–5 spiny neurons to local circuits in macaque primary visual cortex. *Vis. Neurosci.* 13(5):907–22
- Casagrande VA, Kaas JH. 1994. The afferent, intrinsic, and efferent connections of primary visual cortex in primates. In *Cerebral Cortex*, ed. A Peters, KS Rockland, pp. 201–59. New York: Plenum. Vol. 10
- Chatterjee S, Callaway EM. 2003. Parallel colour-opponent pathways to primary visual cortex. *Nature* 426(6967):668–71
- Conway BR. 2001. Spatial structure of cone inputs to color cells in alert macaque primary visual cortex (V-1). *J. Neurosci.* 21(8):2768–83
- Cottaris NP, DeValois RL. 1998. Temporal dynamics of chromatic tuning in macaque primary visual cortex. *Nature* 395(6705):896–900
- Dacey DM, Lee BB. 1994. The ‘blue-on’ opponent pathway in primate retina originates from a distinct bistratified ganglion cell type. *Nature* 367(6465):731–35
- DeYoe EA, VanEssen DC. 1985. Segregation of efferent connections and receptive field properties in visual area V2 of the macaque. *Nature* 317(6032):58–61
- Ding Y, Casagrande VA. 1997. The distribution and morphology of LGN K pathway axons within the layers and CO blobs of owl monkey V1. *Vis. Neurosci.* 14(4):691–704
- Dobkins KR, Thiele A, Albright TD. 2000. Comparison of red-green equiluminance points in humans and macaques: evidence for different L:M cone ratios between species. *J. Opt. Soc. Am. A Opt. Image Sci. Vis.* 17(3):545–56
- Edwards DP, Purpura KP, Kaplan E. 1995. Contrast sensitivity and spatial frequency response of primate cortical neurons in and around the cytochrome oxidase blobs. *Vision Res.* 35(11):1501–23

- Felleman DJ, Van Essen DC. 1991. Distributed hierarchical processing in the primate cerebral cortex. *Cereb. Cortex* 1:1–47
- Fitzpatrick D, Itoh K, Diamond IT. 1983. The laminar organization of the lateral geniculate body and the striate cortex in the squirrel monkey (*Saimiri sciureus*). *J. Neurosci.* 3(4):673–702
- Fitzpatrick D, Usrey WM, Schofield BR, Einstein G. 1994. The sublaminar organization of corticogeniculate neurons in layer 6 of macaque striate cortex. *Vis. Neurosci.* 11(2):307–15
- Friedman HS, Zhou H, von der Heydt R. 2003. The coding of uniform colour figures in monkey visual cortex. *J. Physiol.* 548(Pt. 2):593–613
- Gattass R, Gross CG, Sandell JH. 1981. Visual topography of V2 in the macaque. *J. Comp. Neurol.* 201(4):519–39
- Gattass R, Sousa AP, Mishkin M, Ungerleider LG. 1997. Cortical projections of area V2 in the macaque. *Cereb. Cortex* 7(2):110–29
- Gegenfurtner KR, Kiper DC, Fenstemaker SB. 1996. Processing of color, form, and motion in macaque area V2. *Vis. Neurosci.* 13(1):161–72
- Ghose GM, Yang T, Maunsell JH. 2002. Physiological correlates of perceptual learning in monkey V1 and V2. *J. Neurophysiol.* 87(4):1867–88
- Girard P, Bullier J. 1989. Visual activity in area V2 during reversible inactivation of area 17 in the macaque monkey. *J. Neurophysiol.* 62(6):1287–302
- Gur M, Kagan I, Snodderly DM. 2005. Orientation and direction selectivity of neurons in V1 of alert monkeys: functional relationships and laminar distributions. *Cereb. Cortex*. In press
- Hawken MJ, Parker AJ, Lund JS. 1988. Laminar organization and contrast sensitivity of direction-selective cells in the striate cortex of the Old World monkey. *J. Neurosci.* 8(10):3541–48
- Hendrickson AE, Hunt SP, Wu JY. 1981. Immunocytochemical localization of glutamic acid decarboxylase in monkey striate cortex. *Nature* 292(5824):605–7
- Hendry SH, Reid RC. 2000. The koniocellular pathway in primate vision. *Annu. Rev. Neurosci.* 23:127–53
- Hendry SH, Yoshioka T. 1994. A neurochemically distinct third channel in the macaque dorsal lateral geniculate nucleus. *Science* 264(5158):575–77
- Horton JC, Adams DL. 2005. The cortical column: a structure without a function? *Philos. Trans. R. Soc. London Ser. B*. In press
- Horton JC. 1984. Cytochrome oxidase patches: a new cytoarchitectonic feature of monkey visual cortex. *Philos. Trans. R. Soc. London Ser. B* 304(1119):199–253
- Horton JC, Hoyt WF. 1991. Quadrantic visual field defects. A hallmark of lesions in extrastriate (V2/V3) cortex. *Brain* 114(Pt. 4):1703–18
- Horton JC, Hubel DH. 1981. Regular patchy distribution of cytochrome oxidase staining in primary visual cortex of macaque monkey. *Nature* 292(5825):762–64
- Horton JC, Sincich LC. 2004. How specific is V1 input to V2 thin stripes? *Soc. Neurosci. Abstr.* 34:18.1
- Horwitz GD, Chichilnisky EJ, Albright TD. 2004. Spatial opponency and color tuning dynamics in macaque V1. *Soc. Neurosci. Abstr.* 34:370.9
- Hubel DH, Livingstone MS. 1987. Segregation of form, color, and stereopsis in primate area 18. *J. Neurosci.* 7(11):3378–415
- Hubel DH, Wiesel TN. 1962. Receptive fields, binocular interaction and functional architecture in the cat's visual cortex. *J. Physiol.* 160:106–54
- Hubel DH, Wiesel TN. 1977. Ferrier lecture. Functional architecture of macaque monkey visual cortex. *Proc. R. Soc. London Ser. B* 198(1130):1–59

- Hupe JM, James AC, Girard P, Bullier J. 2001. Response modulations by static texture surround in area V1 of the macaque monkey do not depend on feedback connections from V2. *J. Neurophysiol.* 85(1):146–63
- Ito M, Komatsu H. 2004. Representation of angles embedded within contour stimuli in area V2 of macaque monkeys. *J. Neurosci.* 24(13):3313–24
- Johnson EN, Hawken MJ, Shapley R. 2001. The spatial transformation of color in the primary visual cortex of the macaque monkey. *Nat. Neurosci.* 4(4):409–16
- Kaas JH, Huerta MF, Weber JT, Harting JK. 1978. Patterns of retinal terminations and laminar organization of the lateral geniculate nucleus of primates. *J. Comp. Neurol.* 182(3):517–53
- Kennedy H, Bullier J. 1985. A double-labeling investigation of the afferent connectivity to cortical areas V1 and V2 of the macaque monkey. *J. Neurosci.* 5(10):2815–30
- Kiper DC, Fenstemaker SB, Gegenfurtner KR. 1997. Chromatic properties of neurons in macaque area V2. *Vis. Neurosci.* 14(6):1061–72
- Kobatake E, Tanaka K. 1994. Neuronal selectivities to complex object features in the ventral visual pathway of the macaque cerebral cortex. *J. Neurophysiol.* 71(3):856–67
- Lachica EA, Beck PD, Casagrande VA. 1992. Parallel pathways in macaque monkey striate cortex: anatomically defined columns in layer III. *Proc. Natl. Acad. Sci. USA* 89(8):3566–70
- Landisman CE, Ts'o DY. 2002. Color processing in macaque striate cortex: relationships to ocular dominance, cytochrome oxidase, and orientation. *J. Neurophysiol.* 87(6):3126–37
- Lee BB, Kremers J, Yeh T. 1998. Receptive fields of primate retinal ganglion cells studied with a novel technique. *Vis. Neurosci.* 15:161–75
- Lennie P, Krauskopf J, Sclar G. 1990. Chromatic mechanisms in striate cortex of macaque. *J. Neurosci.* 10(2):649–69
- Leventhal AG, Thompson KG, Liu D, Zhou Y, Ault S. 1995. Concomitant sensitivity to orientation, direction, and color of cells in layers 2, 3, and 4 of monkey striate cortex. *J. Neurosci.* 15(3 Pt. 1):1808–18
- Levitt JB, Kiper DC, Movshon JA. 1994a. Receptive fields and functional architecture of macaque V2. *J. Neurophysiol.* 71(6):2517–42
- Levitt JB, Yoshioka T, Lund JS. 1994b. Intrinsic cortical connections in macaque visual area V2: evidence for interaction between different functional streams. *J. Comp. Neurol.* 342(4):551–70
- Levitt JB, Yoshioka T, Lund JS. 1995. Connections between the pulvinar complex and cytochrome oxidase-defined compartments in visual area V2 of macaque monkey. *Exp. Brain Res.* 104(3):419–30
- Livingstone M, Hubel D. 1988. Segregation of form, color, movement, and depth: anatomy, physiology, and perception. *Science* 240(4853):740–49
- Livingstone MS, Hubel DH. 1982. Thalamic inputs to cytochrome oxidase-rich regions in monkey visual cortex. *Proc. Natl. Acad. Sci. USA* 79(19):6098–101
- Livingstone MS, Hubel DH. 1984a. Anatomy and physiology of a color system in the primate visual cortex. *J. Neurosci.* 4(1):309–56
- Livingstone MS, Hubel DH. 1984b. Specificity of intrinsic connections in primate primary visual cortex. *J. Neurosci.* 4(11):2830–35
- Livingstone MS, Hubel DH. 1987. Connections between layer 4B of area 17 and the thick cytochrome oxidase stripes of area 18 in the squirrel monkey. *J. Neurosci.* 7(11):3371–77
- Lund JS, Angelucci A, Bressloff PC. 2003. Anatomical substrates for functional columns in macaque monkey primary visual cortex. *Cereb. Cortex* 13(1):15–24
- Lund JS, Boothe RG. 1975. Interlaminar connections and pyramidal neuron organization in the visual cortex, area 17, of the macaque monkey. *J. Comp. Neurol.* 159:305–334

- Lund JS, Hendrickson AE, Ogren MP, Tobin EA. 1981. Anatomical organization of primate visual cortex area VII. *J. Comp. Neurol.* 202(1):19–45
- Malach R, Tootell RB, Malonek D. 1994. Relationship between orientation domains, cytochrome oxidase stripes, and intrinsic horizontal connections in squirrel monkey area V2. *Cereb. Cortex* 4(2):151–65
- Martin KA. 1988. From enzymes to visual perception: a bridge too far? *Trends Neurosci.* 11(9):380–87
- Merigan WH, Maunsell JH. 1993. How parallel are the primate visual pathways? *Annu. Rev. Neurosci.* 16:369–402
- Moutoussis K, Zeki S. 2002. Responses of spectrally selective cells in macaque area V2 to wavelengths and colors. *J. Neurophysiol.* 87(4):2104–12
- Movshon JA, Newsome WT. 1996. Visual response properties of striate cortical neurons projecting to area MT in macaque monkeys. *J. Neurosci.* 16(23):7733–41
- Nassi JJ, Callaway EM. 2004. Contributions of magnocellular and parvocellular pathways to neurons in monkey primary visual cortex that provide direct versus indirect input to area MT. *Soc. Neurosci. Abstr.* 34:300.16
- Ohki K, Chung S, Ch'ng YH, Kara P, Reid RC. 2005. Functional imaging with cellular resolution reveals precise micro-architecture in visual cortex. *Nature* 433:597–603
- O'Keefe LP, Levitt JB, Kiper DC, Shapley RM, Movshon JA. 1998. Functional organization of owl monkey lateral geniculate nucleus and visual cortex. *J. Neurophysiol.* 80(2):594–609
- Olavarria J, VanSluyters RC. 1985. Unfolding and flattening the cortex of gyrencephalic brains. *J. Neurosci. Methods* 15(3):191–202
- Olavarria JF, VanEssen DC. 1997. The global pattern of cytochrome oxidase stripes in visual area V2 of the macaque monkey. *Cereb. Cortex* 7(5):395–404
- Perry VH, Oehler R, Cowey A. 1984. Retinal ganglion cells that project to the dorsal lateral geniculate nucleus in the macaque monkey. *Neuroscience* 12(4):1101–23
- Peterhans E, von der Heydt R. 1993. Functional organization of area V2 in the alert macaque. *Eur. J. Neurosci.* 5(5):509–24
- Poggio GF, Gonzalez F, Krause F. 1988. Stereoscopic mechanisms in monkey visual cortex: binocular correlation and disparity selectivity. *J. Neurosci.* 8(12):4531–50
- Reid RC, Shapley RM. 2002. Space and time maps of cone photoreceptor signals in macaque lateral geniculate nucleus. *J. Neurosci.* 22:6158–75
- Ringach DL, Shapley RM, Hawken MJ. 2002. Orientation selectivity in macaque V1: diversity and laminar dependence. *J. Neurosci.* 22:5639–51
- Rockland KS. 1985. A reticular pattern of intrinsic connections in primate area V2 (area 18). *J. Comp. Neurol.* 235(4):467–78
- Rockland KS. 1992. Laminar distribution of neurons projecting from area V1 to V2 in macaque and squirrel monkeys. *Cereb. Cortex* 2(1):38–47
- Rockland KS. 1997. Elements of cortical architecture: hierarchy revisited. In *Cerebral Cortex*, ed. KS Rockland, JH Kaas, A Peters, 12:243–93. New York: Plenum
- Rockland KS, Pandya DN. 1979. Laminar origins and terminations of cortical connections of the occipital lobe in the rhesus monkey. *Brain Res.* 179(1):3–20
- Rockland KS, Pandya DN. 1981. Cortical connections of the occipital lobe in the rhesus monkey: interconnections between areas 17, 18, 19 and the superior temporal sulcus. *Brain Res.* 212(2):249–70
- Rockland KS, Virga A. 1989. Terminal arbors of individual “feedback” axons projecting from area V2 to V1 in the macaque monkey: a study using immunohistochemistry of anterogradely transported Phaseolus vulgaris-leucoagglutinin. *J. Comp. Neurol.* 285(1):54–72

- Rockland KS, Virga A. 1990. Organization of individual cortical axons projecting from area V1 (area 17) to V2 (area 18) in the macaque monkey. *Vis. Neurosci.* 4(1):11–28
- Rodman HR, Sorenson KM, Shim AJ, Hexter DP. 2001. Calbindin immunoreactivity in the geniculo-extrastriate system of the macaque: implications for heterogeneity in the koniocellular pathway and recovery from cortical damage. *J. Comp. Neurol.* 431(2):168–81
- Roe AW, Ts'o DY. 1995. Visual topography in primate V2: multiple representation across functional stripes. *J. Neurosci.* 15(5 Pt. 2):3689–715
- Roe AW, Ts'o DY. 1999. Specificity of color connectivity between primate V1 and V2. *J. Neurophysiol.* 82(5):2719–30
- Sandell JH, Schiller PH. 1982. Effect of cooling area 18 on striate cortex cells in the squirrel monkey. *J. Neurophysiol.* 48(1):38–48
- Sawatari A, Callaway EM. 1996. Convergence of magno- and parvocellular pathways in layer 4B of macaque primary visual cortex. *Nature* 380(6573):442–46
- Sawatari A, Callaway EM. 2000. Diversity and cell type specificity of local excitatory connections to neurons in layer 3B of monkey primary visual cortex. *Neuron* 25(2):459–71
- Schiller PH, Logothetis NK, Charles ER. 1990. Functions of the colour-opponent and broad-band channels of the visual system. *Nature* 343(6253):68–70
- Schiller PH, Malpeli JG. 1977. The effect of striate cortex cooling on area 18 cells in the monkey. *Brain Res.* 126(2):366–69
- Schiller PH, Malpeli JG. 1978. Functional specificity of lateral geniculate nucleus laminae of the rhesus monkey. *J. Neurophysiol.* 41(3):788–97
- Sereno MI, Dale AM, Reppas JB, Kwong KK, Belliveau JW, et al. 1995. Borders of multiple visual areas in humans revealed by functional magnetic resonance imaging. *Science* 268(5212):889–93
- Shapley R, Kaplan E, Soodak R. 1981. Spatial summation and contrast sensitivity of X and Y cells in the lateral geniculate nucleus of the macaque. *Nature* 292(5823):543–45
- Sherman SM, Guillery RW. 1996. Functional organization of thalamocortical relays. *J. Neurophysiol.* 76(3):1367–95
- Shipp S. 2001. Corticopulvinar connections of areas V5, V4, and V3 in the macaque monkey: a dual model of retinal and cortical topographies. *J. Comp. Neurol.* 439(4):469–90
- Shipp S, Zeki S. 1985. Segregation of pathways leading from area V2 to areas V4 and V5 of macaque monkey visual cortex. *Nature* 315(6017):322–25
- Shipp S, Zeki S. 2002a. The functional organization of area V2, I: specialization across stripes and layers. *Vis. Neurosci.* 19(2):187–210
- Shipp S, Zeki S. 2002b. The functional organization of area V2, II: the impact of stripes on visual topography. *Vis. Neurosci.* 19(2):211–31
- Shmuel A, Korman M, Sterkin A, Harel M, Ullman S, et al. 2005. Retinotopic axis specificity and selective clustering of feedback projections from V2 to V1 in the owl monkey. *J. Neurosci.* 25:2117–31
- Sincich LC, Adams DL, Horton JC. 2003. Complete flatmounting of the macaque cerebral cortex. *Vis. Neurosci.* 20(6):663–86
- Sincich LC, Horton JC. 2002a. Divided by cytochrome oxidase: a map of the projections from V1 to V2 in macaques. *Science* 295(5560):1734–37
- Sincich LC, Horton JC. 2002b. Pale cytochrome oxidase stripes in V2 receive the richest projection from macaque striate cortex. *J. Comp. Neurol.* 447(1):18–33
- Sincich LC, Horton JC. 2003. Independent projection streams from macaque striate cortex to the second visual area and middle temporal area. *J. Neurosci.* 23(13):5684–92
- Sincich LC, Park KF, Wohlgenuth MJ, Horton JC. 2004. Bypassing V1: a direct geniculate input to area MT. *Nat. Neurosci.* 7(10):1123–28

- Stettler DD, Das A, Bennett J, Gilbert CD. 2002. Lateral connectivity and contextual interactions in macaque primary visual cortex. *Neuron* 36(4):739–50
- Tamura H, Sato H, Katsuyama N, Hata Y, Tsumoto T. 1996. Less segregated processing of visual information in V2 than in V1 of the monkey visual cortex. *Eur. J. Neurosci.* 8(2):300–9
- Thorell LG, DeValois RL, Albrecht DG. 1984. Spatial mapping of monkey V1 cells with pure color and luminance stimuli. *Vision Res.* 24(7):751–69
- Tigges J, Spatz WB, Tigges M. 1973. Reciprocal point-to-point connections between parastriate and striate cortex in the squirrel monkey (*Saimiri*). *J. Comp. Neurol.* 148(4):481–89
- Tootell RB, Nelissen K, Vanduffel W, Orban GA. 2004. Search for color ‘center(s)’ in macaque visual cortex. *Cereb. Cortex* 14(4):353–63
- Tootell RB, Silverman MS. 1985. Two methods for flat-mounting cortical tissue. *J. Neurosci. Methods* 15(3):177–90
- Tootell RB, Silverman MS, DeValois RL, Jacobs GH. 1983. Functional organization of the second cortical visual area in primates. *Science* 220(4598):737–39
- Ts’o DY, Gilbert CD. 1988. The organization of chromatic and spatial interactions in the primate striate cortex. *J. Neurosci.* 8(5):1712–27
- Ts’o DY, Roe AW, Gilbert CD. 2001. A hierarchy of the functional organization for color, form and disparity in primate visual area V2. *Vision Res.* 41(10–11):1333–49
- Ugolini G. 1995. Specificity of rabies virus as a transneuronal tracer of motor networks: transfer from hypoglossal motoneurons to connected second-order and higher order central nervous system cell groups. *J. Comp. Neurol.* 356(3):457–80
- Valverde F. 1978. The organization of area 18 in the monkey. A Golgi study. *Anat. Embryol. (Berlin)* 154(3):305–34
- Van Essen DC, Gallant JL. 1994. Neural mechanisms of form and motion processing in the primate visual system. *Neuron* 13(1):1–10
- Van Essen DC, Newsome WT, Maunsell JH, Bixby JL. 1986. The projections from striate cortex (V1) to areas V2 and V3 in the macaque monkey: asymmetries, areal boundaries, and patchy connections. *J. Comp. Neurol.* 244(4):451–80
- Vanduffel W, Tootell RB, Schoups AA, Orban GA. 2002. The organization of orientation selectivity throughout macaque visual cortex. *Cereb. Cortex* 12(6):647–62
- Vidyasagar TR, Kulikowski JJ, Lipnicki DM, Dreher B. 2002. Convergence of parvocellular and magnocellular information channels in the primary visual cortex of the macaque. *Eur. J. Neurosci.* 16(5):945–56
- Wachtler T, Sejnowski TJ, Albright TD. 2003. Representation of color stimuli in awake macaque primary visual cortex. *Neuron* 37(4):681–91
- Wade AR, Brewer AA, Rieger JW, Wandell BA. 2002. Functional measurements of human ventral occipital cortex: retinotopy and colour. *Philos. Trans. R. Soc. London Ser. B* 357(1424):963–73
- Weller RE, Kaas JH. 1983. Retinotopic patterns of connections of area 17 with visual areas V-II and MT in macaque monkeys. *J. Comp. Neurol.* 220(3):253–79
- Wiesel TN, Hubel DH. 1966. Spatial and chromatic interactions in the lateral geniculate body of the rhesus monkey. *J. Neurophysiol.* 29(6):1115–56
- Wong-Riley M. 1978. Reciprocal connections between striate and prestriate cortex in squirrel monkey as demonstrated by combined peroxidase histochemistry and autoradiography. *Brain Res.* 147(1):159–64
- Wong-Riley M. 1979. Columnar cortico-cortical interconnections within the visual system of the squirrel and macaque monkeys. *Brain Res.* 162(2):201–17

- Wong-Riley M, Carroll EW. 1984. Effect of impulse blockage on cytochrome oxidase activity in monkey visual system. *Nature* 307(5948):262–64
- Xiao Y, Wang Y, Felleman DJ. 2003. A spatially organized representation of colour in macaque cortical area V2. *Nature* 421(6922):535–39
- Xu X, Bosking W, Sary G, Stefansic J, Shima D, Casagrande VA. 2004. Functional organization of visual cortex in the owl monkey. *J. Neurosci.* 24(28):6237–47
- Yabuta NH, Callaway EM. 1998a. Cytochrome-oxidase blobs and intrinsic horizontal connections of layer 2/3 pyramidal neurons in primate V1. *Vis. Neurosci.* 15(6):1007–27
- Yabuta NH, Callaway EM. 1998b. Functional streams and local connections of layer 4C neurons in primary visual cortex of the macaque monkey. *J. Neurosci.* 18(22):9489–99
- Yabuta NH, Sawatari A, Callaway EM. 2001. Two functional channels from primary visual cortex to dorsal visual cortical areas. *Science* 292(5515):297–300
- Yazar F, Mavity-Hudson J, Ding Y, Oztas E, Casagrande VA. 2004. Layer IIIB-beta of primary visual cortex (V1) and its relationship to the koniocellular (K) pathway in macaque. *Soc. Neurosci. Abstr.* 34:300.17
- Yoshioka T, Blasdel GG, Levitt JB, Lund JS. 1996. Relation between patterns of intrinsic lateral connectivity, ocular dominance, and cytochrome oxidase-reactive regions in macaque monkey striate cortex. *Cereb. Cortex* 6(2):297–310
- Yoshioka T, Dow BM. 1996. Color, orientation and cytochrome oxidase reactivity in areas V1, V2 and V4 of macaque monkey visual cortex. *Behav. Brain Res.* 76(1–2):71–88
- Yoshioka T, Levitt JB, Lund JS. 1994. Independence and merger of thalamocortical channels within macaque monkey primary visual cortex: anatomy of interlaminar projections. *Vis. Neurosci.* 11(3):467–89
- Yukie M, Iwai E. 1981. Direct projection from the dorsal lateral geniculate nucleus to the prestriate cortex in macaque monkeys. *J. Comp. Neurol.* 201(1):81–97



# Contents

Genetics of Brain Structure and Intelligence <i>Arthur W. Toga and Paul M. Thompson</i> .....	1
The Actin Cytoskeleton: Integrating Form and Function at the Synapse <i>Christian Dillon and Yukiko Goda</i> .....	25
Molecular Pathophysiology of Parkinson's Disease <i>Darren J. Moore, Andrew B. West, Valina L. Dawson, and Ted M. Dawson</i> .....	57
Large-Scale Genomic Approaches to Brain Development and Circuitry <i>Mary E. Hatten and Nathaniel Heintz</i> .....	89
Autism: A Window Onto the Development of the Social and the Analytic Brain <i>Simon Baron-Cohen and Matthew K. Belmonte</i> .....	109
Axon Retraction and Degeneration in Development and Disease <i>Liqun Luo and Dennis D.M. O'Leary</i> .....	127
Structure and Function of Visual Area MT <i>Richard T. Born and David C. Bradley</i> .....	157
Growth and Survival Signals Controlling Sympathetic Nervous System Development <i>Natalia O. Glebova and David D. Ginty</i> .....	191
Adult Neurogenesis in the Mammalian Central Nervous System <i>Guo-li Ming and Hongjun Song</i> .....	223
Mechanisms of Vertebrate Synaptogenesis <i>Clarissa L. Waites, Ann Marie Craig, and Craig C. Garner</i> .....	251
Olfactory Memory Formation in <i>Drosophila</i> : From Molecular to Systems Neuroscience <i>Ronald L. Davis</i> .....	275
The Circuitry of V1 and V2: Integration of Color, Form, and Motion <i>Lawrence C. Sincich and Jonathan C. Horton</i> .....	303

Molecular Gradients and Development of Retinotopic Maps <i>Todd McLaughlin and Dennis D.M. O'Leary</i> .....	327
Neural Network Dynamics <i>Tim P. Vogels, Kanaka Rajan, and L.F. Abbott</i> .....	357
The Plastic Human Brain Cortex <i>Alvaro Pascual-Leone, Amir Amedi, Felipe Fregni, and Lotfi B. Merabet</i> .....	377
An Integrative Theory of Locus Coeruleus-Norepinephrine Function: Adaptive Gain and Optimal Performance <i>Gary Aston-Jones and Jonathan D. Cohen</i> .....	403
Neuronal Substrates of Complex Behaviors in <i>C. elegans</i> <i>Mario de Bono and Andres Villu Maricq</i> .....	451
Dendritic Computation <i>Michael London and Michael Häusser</i> .....	503
Optical Imaging and Control of Genetically Designated Neurons in Functioning Circuits <i>Gero Miesenböck and Ioannis G. Kevrekidis</i> .....	533

## INDEXES

Subject Index .....	565
Cumulative Index of Contributing Authors, Volumes 19–28 .....	577
Cumulative Index of Chapter Titles, Volumes 19–28 .....	582

## ERRATA

An online log of corrections to *Annual Review of Neuroscience* chapters may be found at <http://neuro.annualreviews.org/>